

QMS-00051

Typical Specification

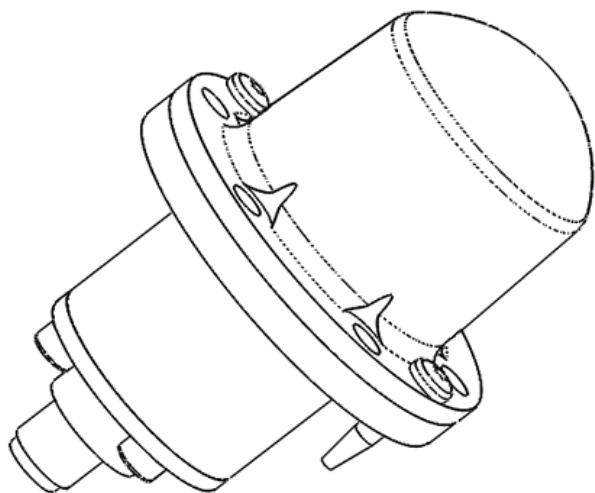

Frequency	18 to 42 GHz
Connector	K-type (2.92mm) female
VSWR	Typically < 2.5 :1
Gain	2.2 to 6.5 dBi
Axial Ratio	0.4 to 3.2 dB
3 dB Beamwidth	37.4 to 83.8 degrees
10 dB Beamwidth	72.8 to 126.5 degrees
Power	2 Watt c.w.
Size & Weight	35.5mm x 54.2mm (D x H), 44g
Mounting	6 x Ø 3.2mm Thru on Ø 30mm PCD
Environmental	Please contact Steatite for advice.

Please contact Steatite Antennas for a full interface control drawing.

Typical Gain

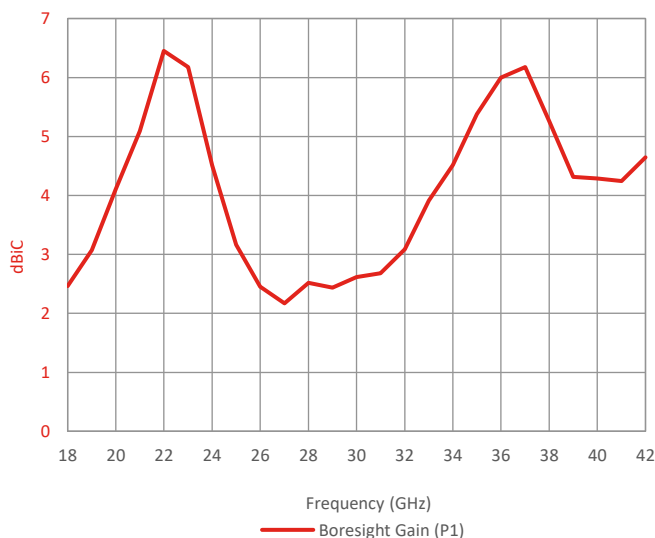

Typical Beamwidth

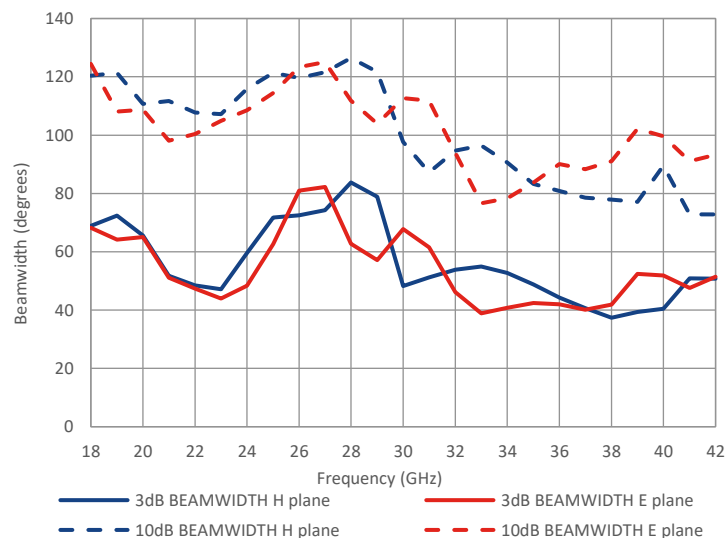

Typical VSWR

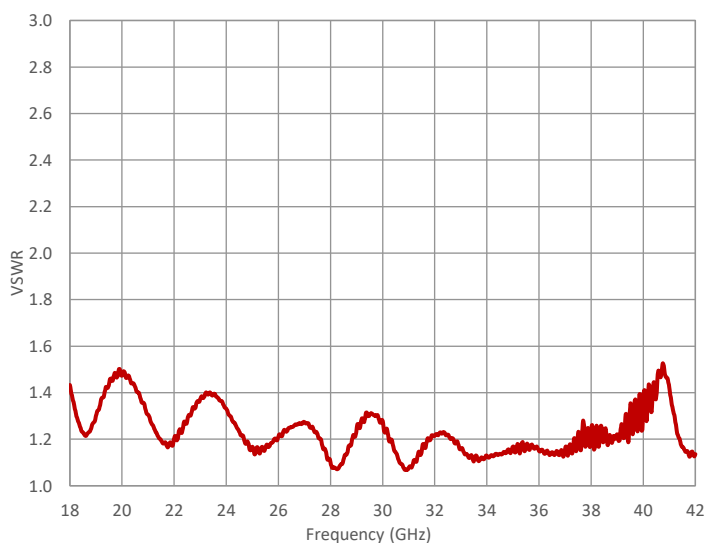

Typical Axial Ratio

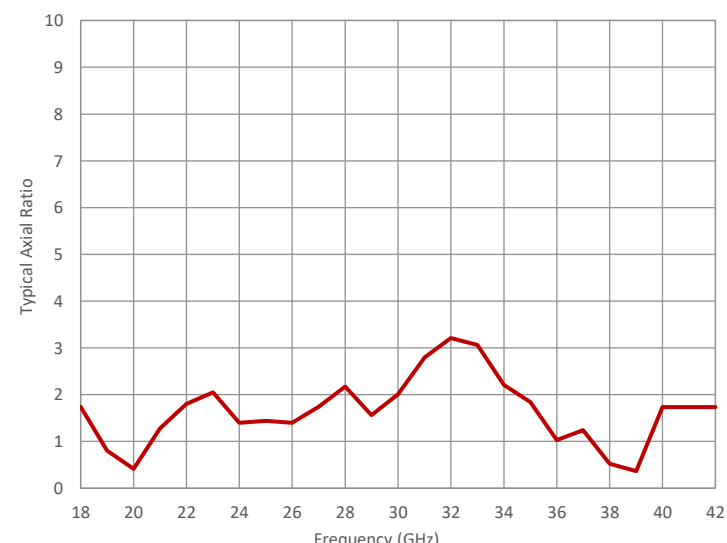

Steatite Antennas reserve the right to change and/or update this specification whereby it is deemed that this would improve either the production and/or performance specification of this part. Information herein should not be disclosed to a third party without the prior written consent of Steatite Antennas.

BP 12/06/2024 3133

