

1.5 m Carbon Fibre Reflector & 0.5-2 GHz Wideband Feed fitted with an N type Connector and Radome

QMS-01186

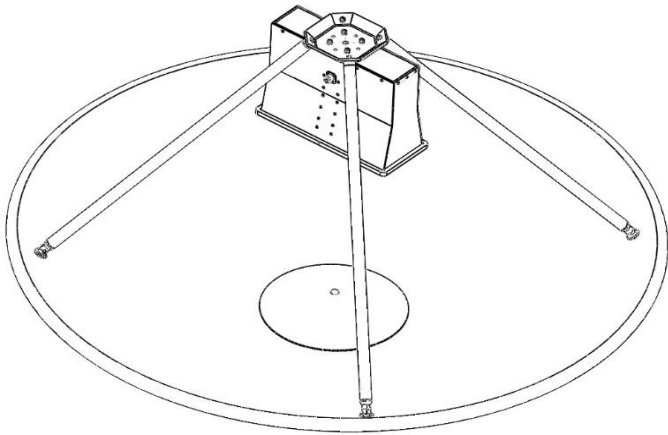

Please contact Steatite Antennas for a full interface control drawing.

Typical Specification

Frequency	0.5 to 2 GHz
Connector	N- Type Female
VSWR	Typically <2.5:1 (< 3.0:1 Max)
Gain	14.3 to 24.8 dBi
Antenna Factor	9.9 to 11.5 dB/m
3 dB Beamwidth	5.6 to 33.1 degrees
10 dB Beamwidth	10 to 62 degrees
Power	400W CW Typical
Size & Weight	Refer to ICD
Mounting	Refer to ICD
Environmental	Contact Steatite for further information

Typical Gain

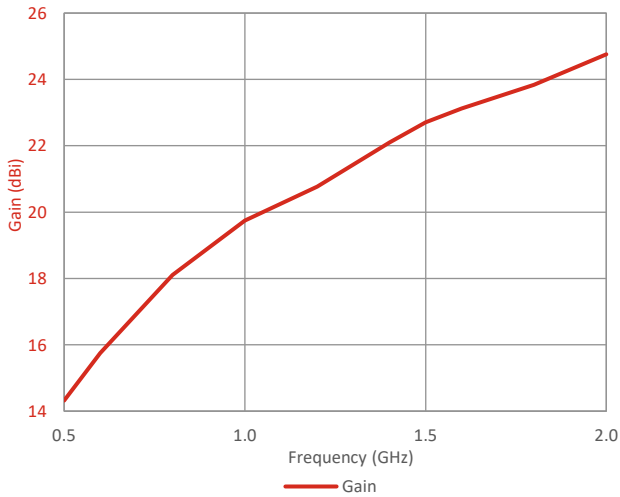

Typical Beamwidth

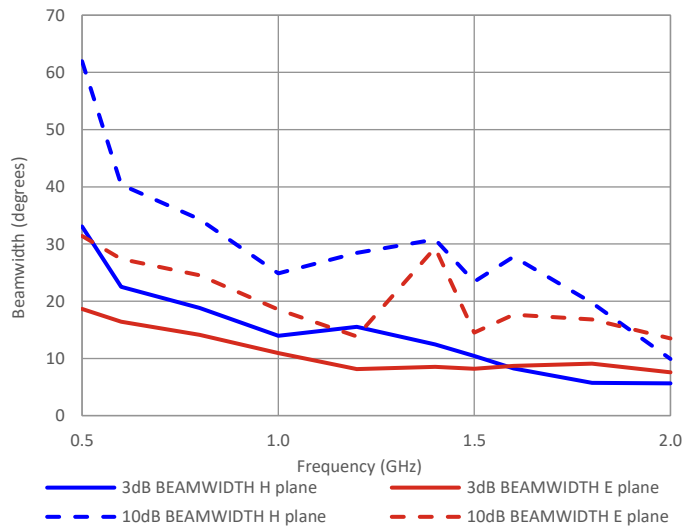

Typical VSWR

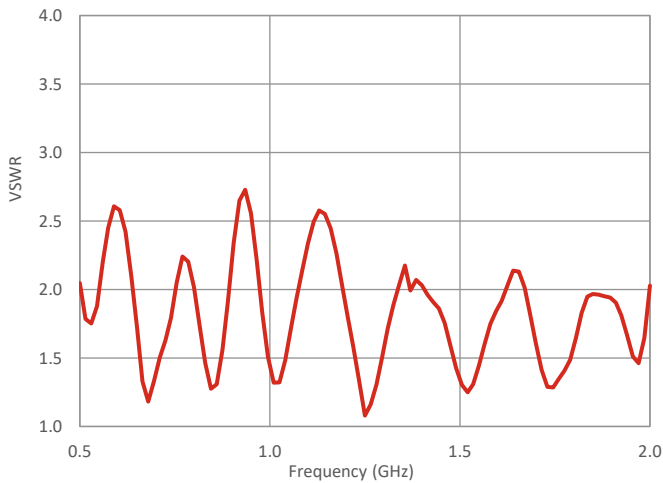

Typical Antenna Factor

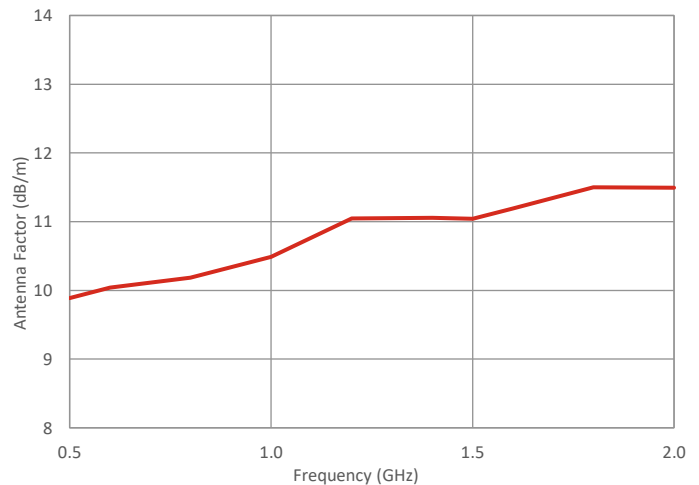

Steatite Antennas reserve the right to change and/or update this specification whereby it is deemed that this would improve either the production and/or performance specification of this part. Information herein should not be disclosed to a third party without the prior written consent of Steatite Antennas.

