

2 - 18 GHz Linearly Polarised High Gain Wideband Ridged Horn Antenna fitted with an SMA type Connector and Radome

Catalogue number **QWH-SL-2-18-S-HG-R**

Q-par reference **QMS-00477**

Contents **Summary**
Typical Gain / Antenna Factor
Typical Beamwidth / Patterns
VSWR

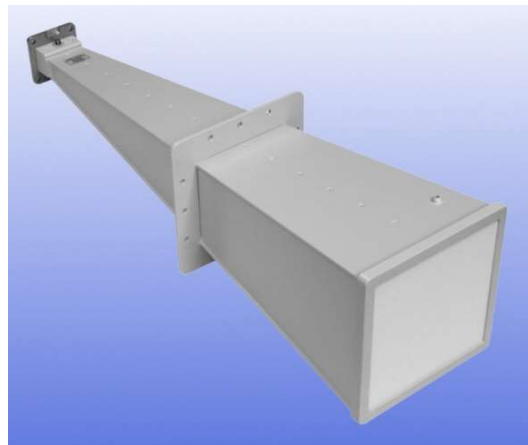

Typical Specification

Frequency	2 to 18 GHz
Connector Type	SMA type jack
Power Handling	20 Watt c.w.
VSWR	< 2.0:1 over 90% band. Typically < 3.5:1 at 2 GHz
Gain	9 to 23 dBi
Antenna Factor	24 to 35 dB/m
3dB Beamwidth	9 to 52 degrees
10dB Beamwidth	17 to 104 degrees
Weight	2.4 kg
Maximum Size	166 mm x 166 mm ext. aperture, 620 mm long
Mounting	Rear mount plate with 4 holes diameter 5.2 mm, 50 mm centres. Centre of gravity mount plate with 3 holes, diameter 6 mm , 35 mm spacing, on all four sides.
Construction	Aluminium & engineering plastics. Painted

Typical Antenna Gain / Factor

This is calculated by reference to standard gain horn antennas, and cross checked with reference to the antenna beamwidth, with an estimated error of +/- 1.0 dB.

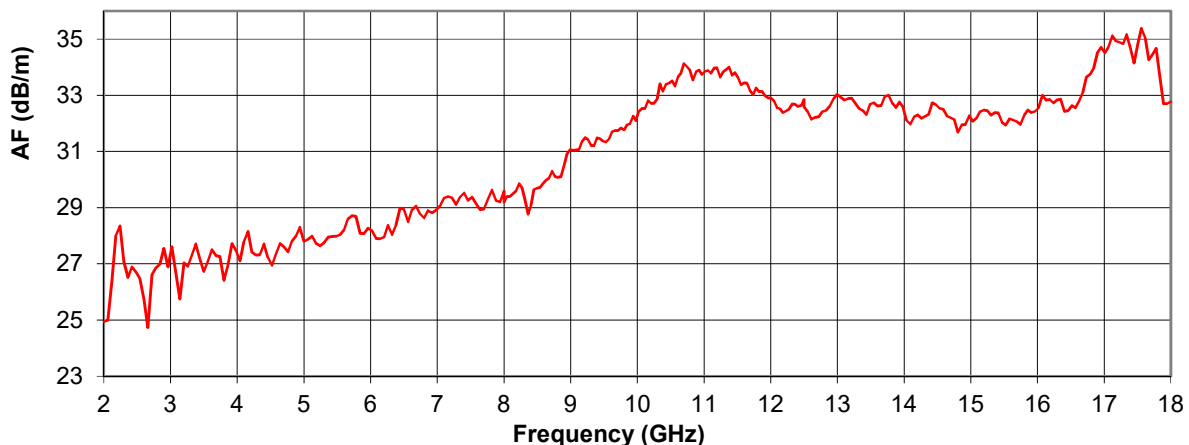
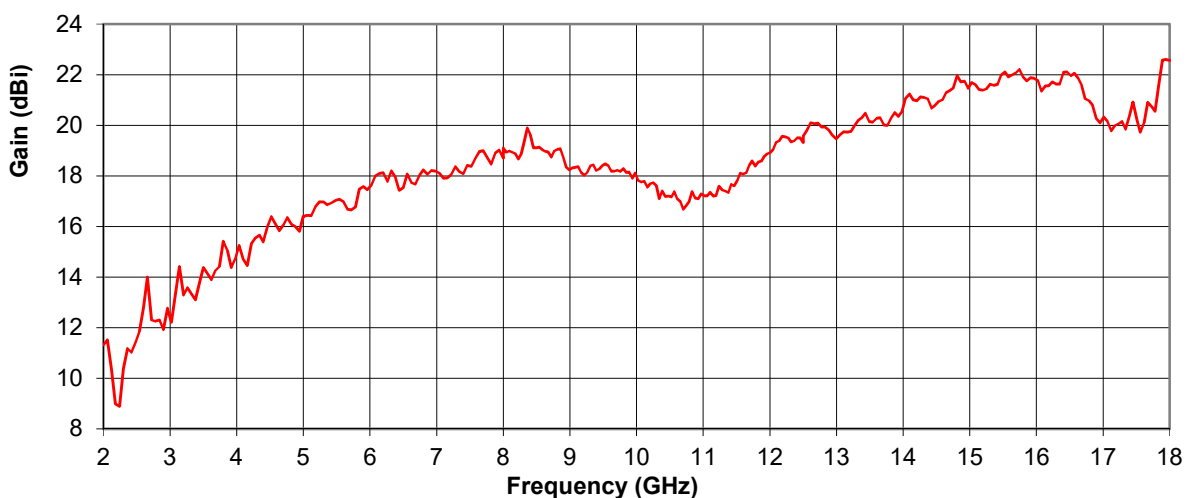

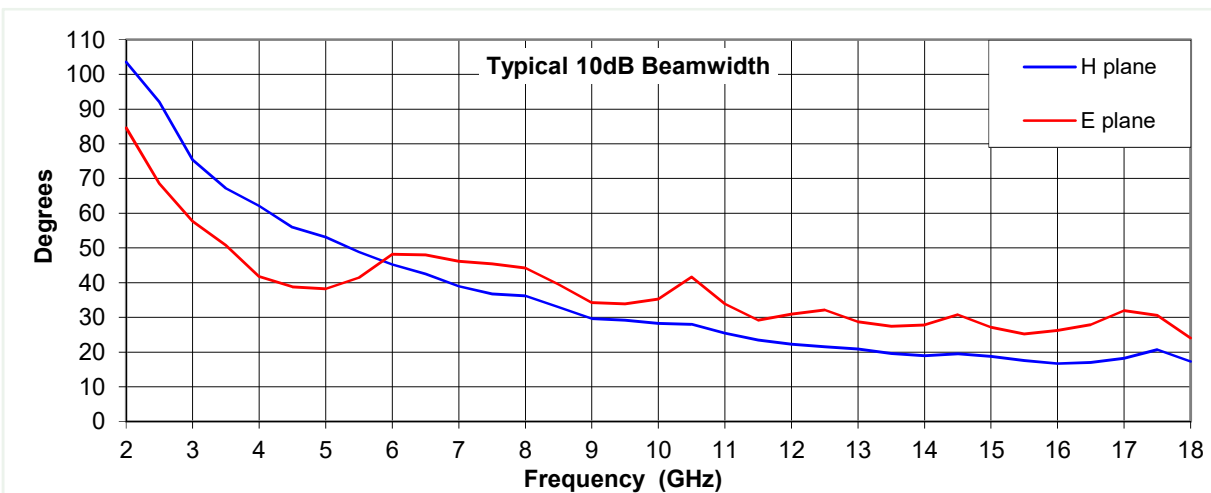
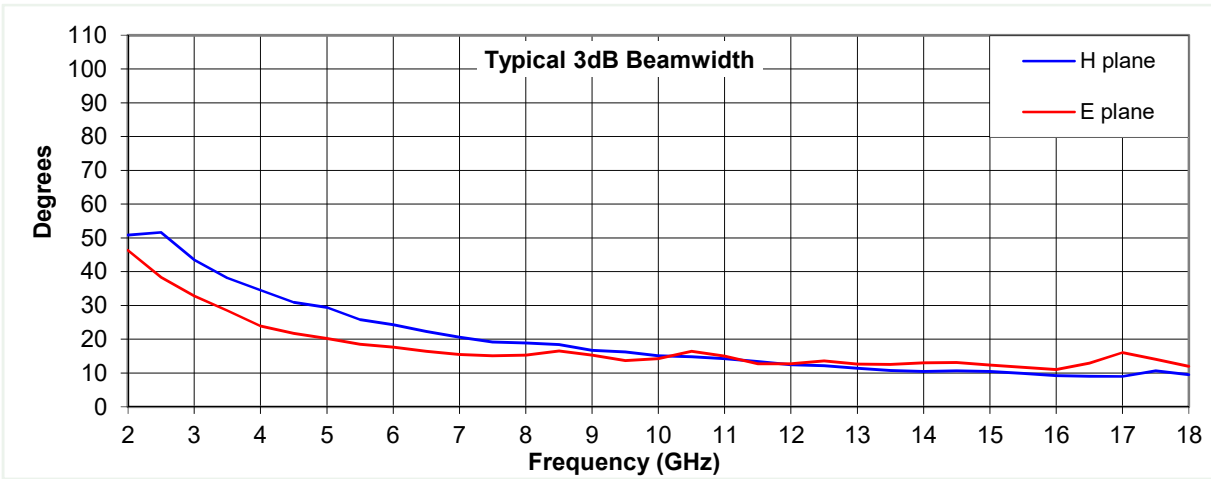

2 GHz

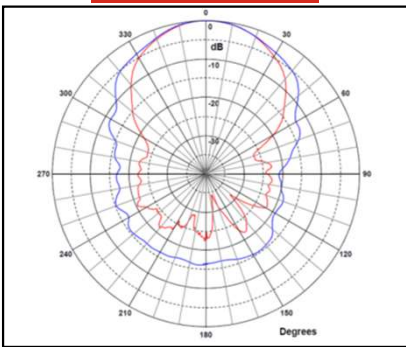

6 GHz

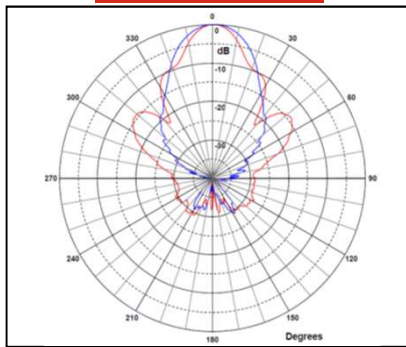

10 GHz

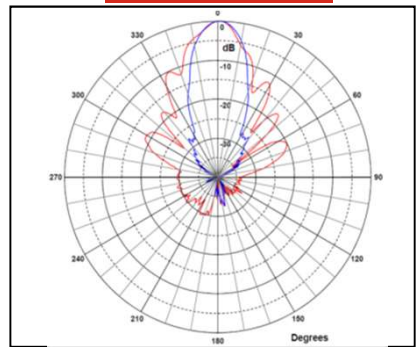

14 GHz

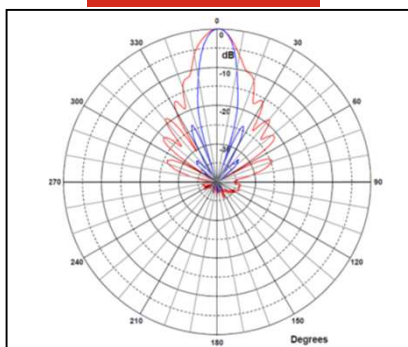

18 GHz

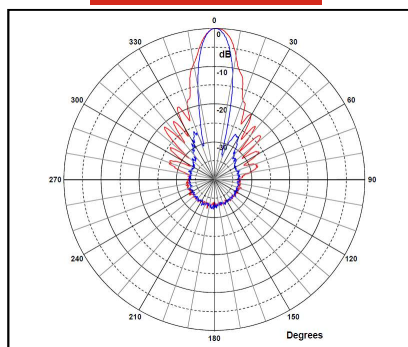

Red trace = E-plane, Blue trace = H-plane cut